

New Product Introduction:

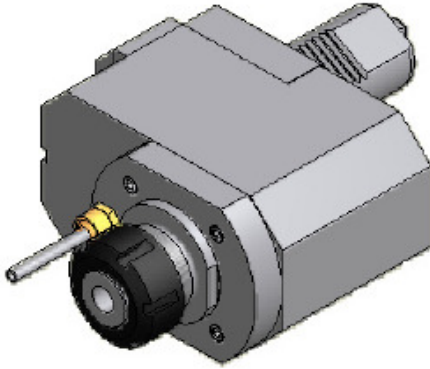

Planet Products Introduces High Speed Live Tooling.

Developed for applications requiring high rpm in a precision heavy duty package, Planet products offers turret lathe live tooling in 2:1 and 3:1 speed up ratios. These unique, patent pending tools are especially effective at running long duty cycles at high speeds due to their proprietary bearing cooling system. By keeping the precision bearings at a constant temperature, the internal components are set to tighter tolerances, and are able to maintain accuracy over long cycles and production runs. Customer trials have reported ability to run longer milling cycles and extended service intervals.

Planet Products Corporation of Cincinnati, Ohio has produced machine tools and innovative engineered solutions for industry since 1947. (513) 984-5544, www.planet-products.com